

SYM.	PART #	DESCRIPTION	QTY
1	AB5243(6P-S)HD	TM 12 ASSY w/6"PLT, HDG	1
2	AS REQ'D	MAST ASSY, HDG (MAST O.D. & LENGTH as req'd)	1
3	PC406CC50	PIPE CLAMP(4.06C-C), HDG	4
4	B1346-6HDGA449	1/2" x 6" THREADED ROD A449 HDG	8
5	H1-0500-125A325HDG	1/2"x1-1/4" BOLT A325, HDG	4
6	H4-0500LWHDG	1/2" LOCKWASHER, HDG	20
7	H3-0500FVHDG	1/2" FLATWASHER, HDG	8
8	H2-0500HN2HHDG	1/2" HVYNUT 2H, HDG	20

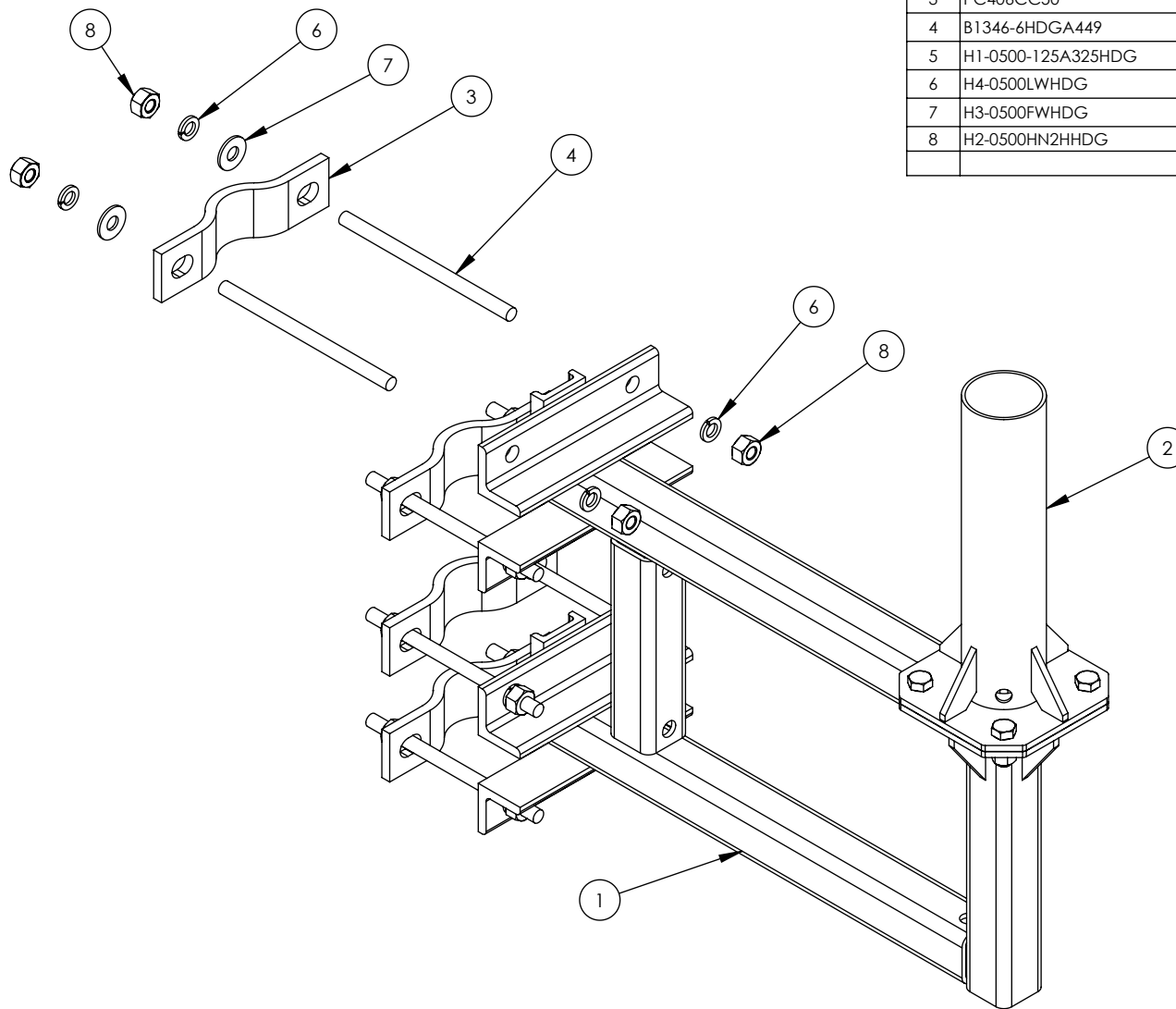

MOUNT WILL CLAMP TO 1.90"OD -3.50"OD TOWER LEG  
TOWER LEG NOT SHOWN

**PROPRIETARY AND CONFIDENTIAL**  
THE INFORMATION CONTAINED IN THIS DRAWING IS THE SOLE PROPERTY OF BAIRD SUPPORTING SYSTEMS. ANY REPRODUCTION IN PART OR AS A WHOLE WITHOUT THE WRITTEN PERMISSION OF BAIRD SUPPORTING SYSTEMS IS PROHIBITED.



WWW.BAIRD MOUNTS.COM

UNLESS OTHERWISE SPECIFIED:  
DIMENSIONS ARE IN INCHES  
TOLERANCES:  
FRACTIONAL ±  
TWO PLACE DECIMAL ±  
THREE PLACE DECIMAL ±  
ANGULAR: MACH ± BEND ±

DO NOT SCALE DRAWING

**BAIRD MOUNTING SYSTEMS**

WATERLOO, IA 50703  
PHONE: 319-233-3561  
SALES@BAIRDMOUNTS.COM

TITLE:  
TOWER MOUNT FOR 1.2M ANTENNA  
FOR TOWER LEG 1.90"OD TO 3.5"OD

DRAWN BY JK	DATE 04/07/21
MATERIAL STEEL	FINISH HDG
DWG. PURPOSE CUSTOMER	SHEET 1
	SCALE -
PART. NO. TM12P6S-(000)X(0)	
DWG. NO. TM12P6S-(000)X(0) INST	