

B6116-(000)X(0) with Pad

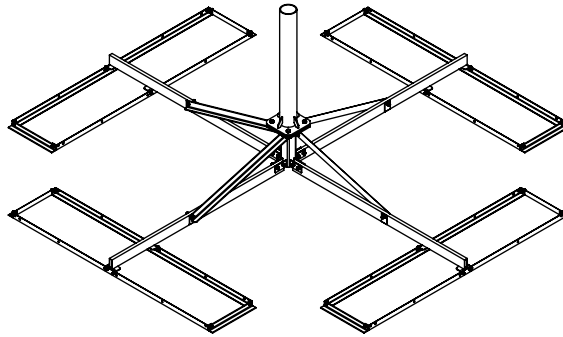

PART LIST			
SYM	PART #	DESCRIPTION	QTY.
1	as required	MAST (O.D. &Length as req'd)	1
2	AB1510HD	B611 BASE ASS'Y, HDG	1
3	AB1509HD	B611 BRACE 35.75'L, HDG	4
4	AB1508C1HD	B611 ARM ASS'Y, HDG	4
5	AB1119B(1.5L)HD	6'BALLAST PAD(1.5L),HDG	8
6	AB1425HD	16" SIDE PAD(1.5L), HDG	8
7	H1-0750-200G5Z	3/4"x2" BOLT GR.5, Z/P	4
8	H2-0750HN	3/4" NUT, Z/P	4
9	H4-0750LW	3/4" LOCKWASHER, Z/P	4

HDWE-MH7
QTY.1

SYM	PART #	DESCRIPTION	QTY.
10	H1-0500-125	1/2" x 1-1/4" BOLT GR.5, Z/P	4
11	H1-0500-225	1/2" x 2-1/4" BOLT GR.5, Z/P	12
12	H2-0500HN	1/2" NUT, Z/P	16
13	H4-0500LW	1/2" LOCKWASHER, Z/P	16
14	H1-0375-100	3/8" x 1" BOLT GR.5, Z/P	32
15	H2-0375HN	3/8" NUT, Z/P	32
16	H4-0375LW	3/8" LOCKWASHER, Z/P	32
		1/8" RUBBER PAD 18"x48"	8
		PALLET	1

HDWE-B6
QTY.1

HDWE-BT
QTY.2

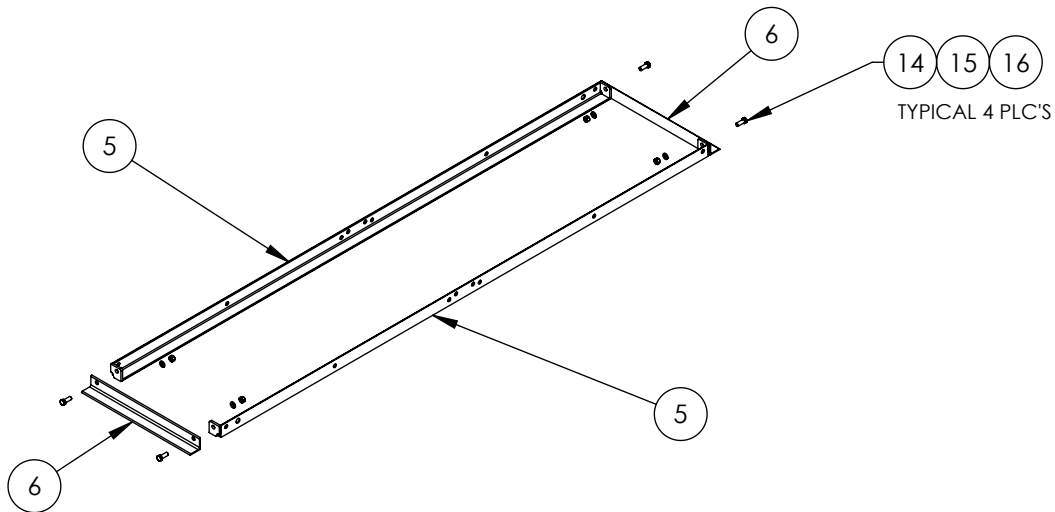

ASSEMBLE FOUR BALLAST TRAYS (ONE SHOWN ABOVE). EACH BALLAST TRAY CONSISTS OF TWO 6' BALLAST ANGLES(#5) AND TWO SIDE PADS(#6). ASSEMBLE EACH TRAY USING FOUR 3/8"x1" BOLTS (#14), NUTS(#15) AND LOCKWASHERS(#16)

PROPRIETARY AND CONFIDENTIAL

THE INFORMATION CONTAINED IN THIS DRAWING IS THE SOLE PROPERTY OF BAIRD SUPPORTING SYSTEMS. ANY REPRODUCTION IN PART OR AS A WHOLE WITHOUT THE WRITTEN PERMISSION OF BAIRD SUPPORTING SYSTEMS IS PROHIBITED.



WWW.BAIRD MOUNTS.COM

UNLESS OTHERWISE SPECIFIED:

DIMENSIONS ARE IN INCHES
TOLERANCES:
FRACTIONAL ±
ANGULAR: MACH ± BEND ±
TWO PLACE DECIMAL ±
THREE PLACE DECIMAL ±

DO NOT SCALE DRAWING

BAIRD MOUNTING SYSTEMS

WATERLOO, IA 50703
PHONE: 319-233-3561
SALES@BAIRDMOUNTS.COM

TITLE:
B6-116 with Pad Assembly

DRAWN BY JK	DATE 04/19/19
MATERIAL -	FINISH -
DWG. PURPOSE INST	SHEET 1
	SCALE -
PART. NO. B6116-(000)X(0)-R	
DWG. NO. B6116-(000)X(0)-R Assembly Instruction	

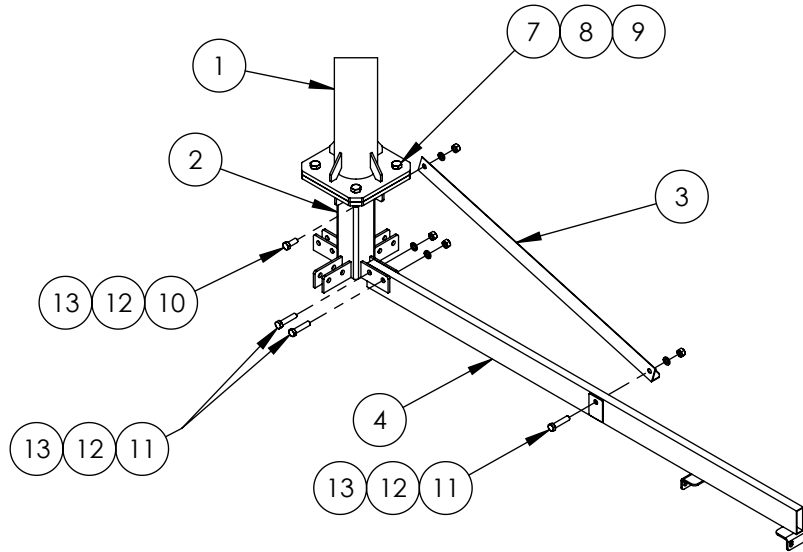

ATTACH THE ARM ASSY(#4) TO THE LOWER FINS ON THE BASE(#2) USING TWO 1/2"x2-1/4" BOLTS, NUTS AND LOCKWASHERS.

ATTACH THE BRACE(#3) TO THE UPPER FIN ON THE BASE USING ONE 1/2"x1-1/4" BOLT, NUT AND LOCKWASHER. SECURE THE OTHER END OF THE BRACE TO THE ARM(#4) USING ONE 1/2"x2-1/4" BOLT, NUT AND LOCKWASHER.

REPEAT THE TWO STEPS FOR THE REMAINING THREE LEGS OF THE MOUNT.

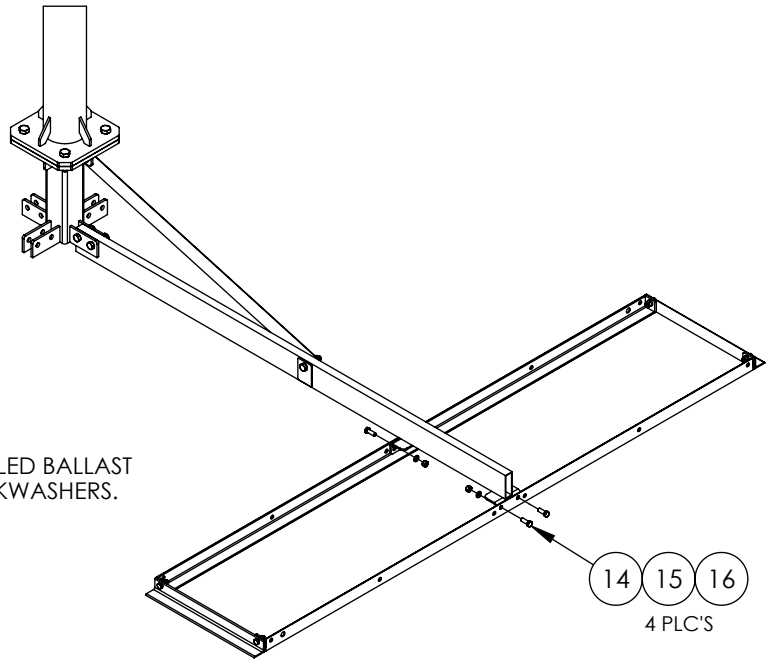

ATTACH EACH ARM TO THE PREVIOUSLY ASSEMBLED BALLAST TRAY USING FOUR 3/8"x1" BOLTS, NUTS AND LOCKWASHERS.

PROPRIETARY AND CONFIDENTIAL

THE INFORMATION CONTAINED IN THIS DRAWING IS THE SOLE PROPERTY OF BAIRD SUPPORTING SYSTEMS. ANY REPRODUCTION IN PART OR AS A WHOLE WITHOUT THE WRITTEN PERMISSION OF BAIRD SUPPORTING SYSTEMS IS PROHIBITED.



WWW.BAIRD MOUNTS.COM

UNLESS OTHERWISE SPECIFIED:

DIMENSIONS ARE IN INCHES
 TOLERANCES:
 FRACTIONAL ±
 ANGULAR: MACH ± BEND ±
 TWO PLACE DECIMAL ±
 THREE PLACE DECIMAL ±

DO NOT SCALE DRAWING

BAIRD MOUNTING SYSTEMS

WATERLOO, IA 50703
 PHONE: 319-233-3561
 SALES@BAIRDMOUNTS.COM

TITLE:
B6-116 with Pad Assembly

DRAWN BY JK	DATE 10/05/18	
MATERIAL -	FINISH -	
DWG. PURPOSE INST	SHEET 2	SCALE -
PART. NO. B6116-(000)X(0)-R		
DWG. NO. B6116-(000)X(0)-R Assembly Instruction		

PART NO.	MAST DIAMETER	WEIGHT
B6116-237X3	2.37" OD	192 lbs.
B6116-288X3	2.88" OD	198 lbs.
B6116-400X3	4.00" OD	209 lbs.
B6116-450X3	4.50" OD	214 lbs.
B6116-550X3	5.50" OD	244 lbs.
B6116-556X3	5.56" OD	226 lbs.
B6116-662X3	6.62" OD	240 lbs.

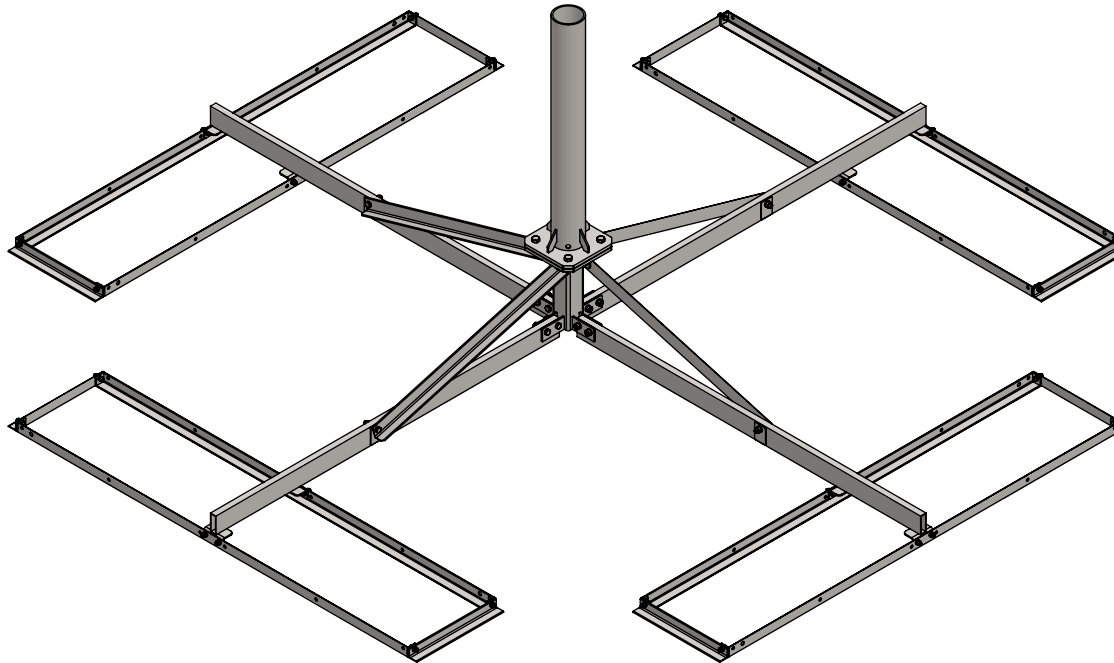

PROPRIETARY AND CONFIDENTIAL

THE INFORMATION CONTAINED IN THIS DRAWING IS THE SOLE PROPERTY OF BAIRD SUPPORTING SYSTEMS. ANY REPRODUCTION IN PART OR AS A WHOLE WITHOUT THE WRITTEN PERMISSION OF BAIRD SUPPORTING SYSTEMS IS PROHIBITED.



WWW.BAIRD MOUNTS.COM

UNLESS OTHERWISE SPECIFIED:

DIMENSIONS ARE IN INCHES

TOLERANCES:

FRACTIONAL ±

ANGULAR: MACH ± BEND ±

TWO PLACE DECIMAL ±

THREE PLACE DECIMAL ±

DO NOT SCALE DRAWING

BAIRD MOUNTING SYSTEMS

WATERLOO, IA 50703
 PHONE: 319-233-3561
 SALES@BAIRD MOUNTS.COM

DESCRIPTION:

B6-116 MOUNT WITH 3' MAST

DRAWN BY

JK

MATERIAL

STEEL

DWG. PURPOSE

CUSTOMER

DATE

02/17/22

FINISH

HDG

SHEET

1 OF 2

SCALE

-

PART. NO.

SEE TABLE

DWG. NO.

B6116-(000)X3

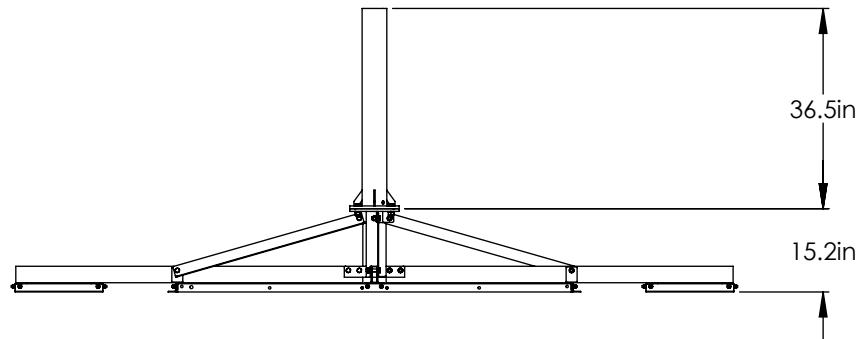
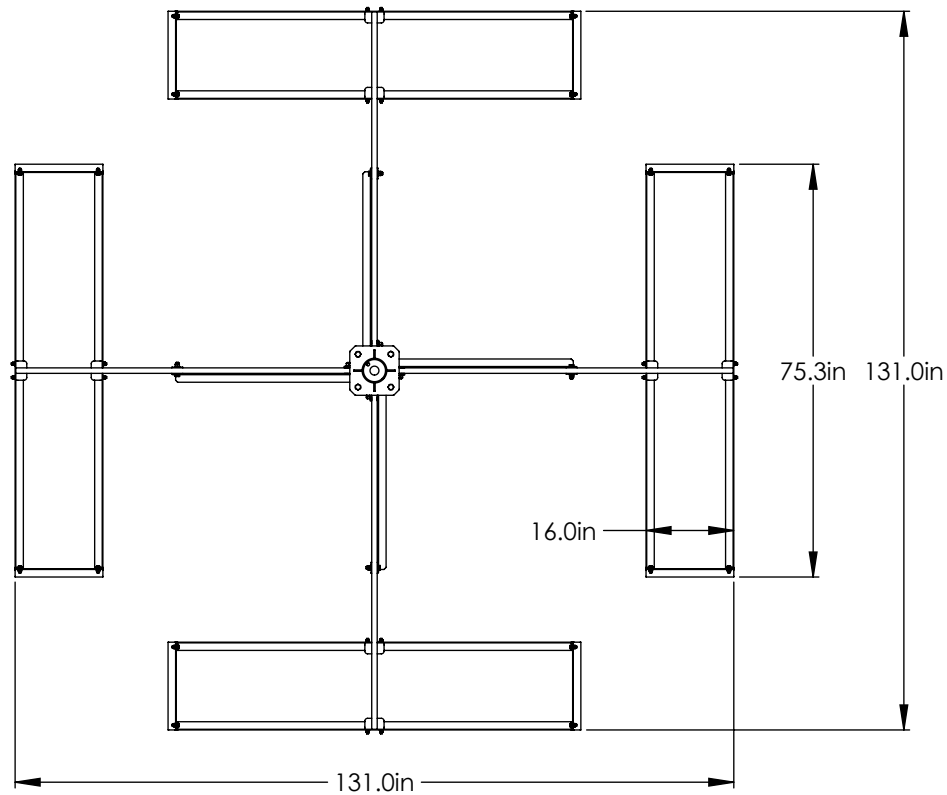

PROPRIETARY AND CONFIDENTIAL
 THE INFORMATION CONTAINED IN THIS DRAWING IS THE SOLE PROPERTY OF BAIRD SUPPORTING SYSTEMS. ANY REPRODUCTION IN PART OR AS A WHOLE WITHOUT THE WRITTEN PERMISSION OF BAIRD SUPPORTING SYSTEMS IS PROHIBITED.



WWW.BAIRD MOUNTS.COM

UNLESS OTHERWISE SPECIFIED:
 DIMENSIONS ARE IN INCHES
 TOLERANCES:
 FRACTIONAL ±
 ANGULAR: MACH ± BEND ±
 TWO PLACE DECIMAL ±
 THREE PLACE DECIMAL ±

DO NOT SCALE DRAWING

BAIRD MOUNTING SYSTEMS

WATERLOO, IA 50703
 PHONE: 319-233-3561
 SALES@BAIRD MOUNTS.COM

DESCRIPTION:
 B6-116 MOUNT WITH 3' MAST

DRAWN BY JK	DATE 02/17/22
MATERIAL STEEL	FINISH HDG
DWG. PURPOSE CUSTOMER	SHEET 2OF2
	SCALE -

PART. NO.
 SEE TABLE-SHEET 1

DWG. NO.
 B6116-(000)X3

PART NO.	MAST DIAMETER	WEIGHT
B6116-237X5	2.37" OD	200 lbs.
B6116-288X5	2.88" OD	211 lbs.
B6116-450X5	4.50" OD	237 lbs.

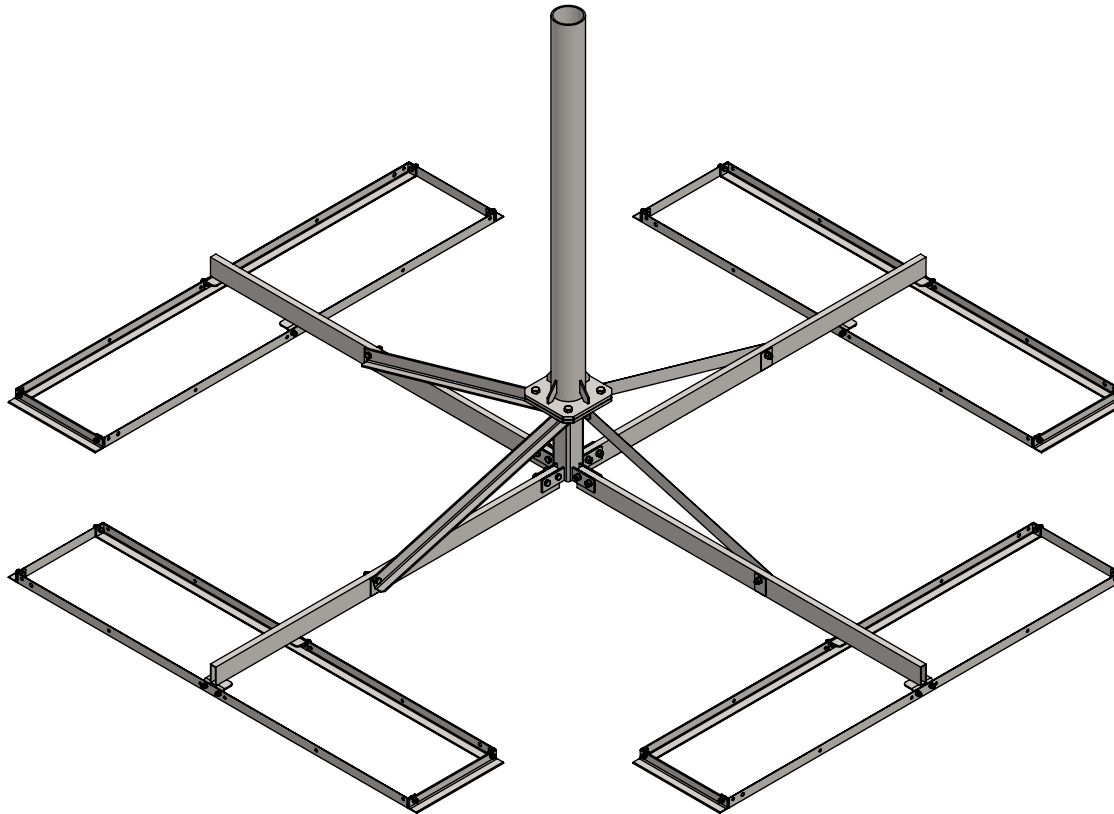

PROPRIETARY AND CONFIDENTIAL
 THE INFORMATION CONTAINED IN THIS DRAWING IS THE SOLE PROPERTY OF BAIRD SUPPORTING SYSTEMS. ANY REPRODUCTION IN PART OR AS A WHOLE WITHOUT THE WRITTEN PERMISSION OF BAIRD SUPPORTING SYSTEMS IS PROHIBITED.



WWW.BAIRD MOUNTS.COM

UNLESS OTHERWISE SPECIFIED:
 DIMENSIONS ARE IN INCHES
 TOLERANCES:
 FRACTIONAL ±
 ANGULAR: MACH ± BEND ±
 TWO PLACE DECIMAL ±
 THREE PLACE DECIMAL ±

DO NOT SCALE DRAWING

BAIRD MOUNTING SYSTEMS

WATERLOO, IA 50703
 PHONE: 319-233-3561
 SALES@BAIRD MOUNTS.COM

DESCRIPTION:

B6-116 MOUNT WITH 5' MAST

DRAWN BY JK	DATE 02/17/22
MATERIAL STEEL	FINISH HDG
DWG. PURPOSE CUSTOMER	SHEET 1OF2
	SCALE -

PART. NO.
SEE TABLE

DWG. NO.
B6116-(000)X5

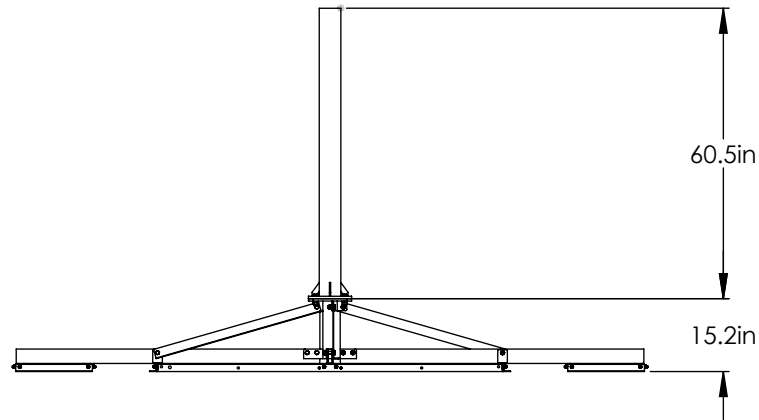
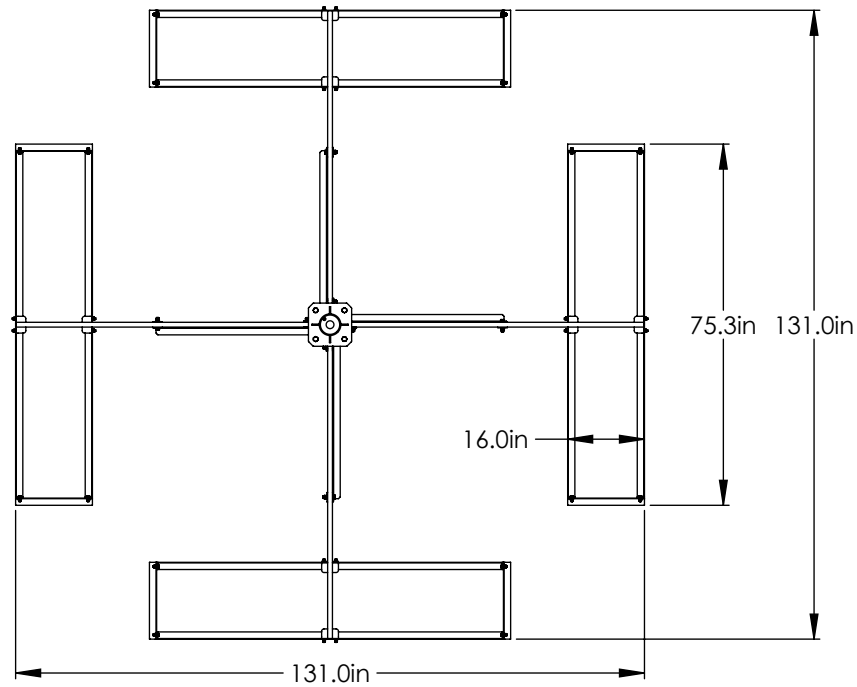

PROPRIETARY AND CONFIDENTIAL
 THE INFORMATION CONTAINED IN THIS DRAWING IS THE SOLE PROPERTY OF BAIRD SUPPORTING SYSTEMS. ANY REPRODUCTION IN PART OR AS A WHOLE WITHOUT THE WRITTEN PERMISSION OF BAIRD SUPPORTING SYSTEMS IS PROHIBITED.



WWW.BAIRD MOUNTS.COM

UNLESS OTHERWISE SPECIFIED:
 DIMENSIONS ARE IN INCHES
 TOLERANCES:
 FRACTIONAL ±
 ANGULAR: MACH ± BEND ±
 TWO PLACE DECIMAL ±
 THREE PLACE DECIMAL ±

DO NOT SCALE DRAWING

BAIRD MOUNTING SYSTEMS

WATERLOO, IA 50703
 PHONE: 319-233-3561
 SALES@BAIRD MOUNTS.COM

DESCRIPTION:
 B6-116 MOUNT WITH 5' MAST

DRAWN BY JK	DATE 02/17/22
MATERIAL STEEL	FINISH HDG
DWG. PURPOSE CUSTOMER	SHEET 2OF2
	SCALE -

PART. NO.
 SEE TABLE-SHEET 1

DWG. NO.
 B6116-(000)X5

PART NO.	MAST DIAMETER	WEIGHT
B6116-237X8	2.37" OD	211 lbs.
B6116-288X8	2.88" OD	229 lbs.
B6116-450X8	4.50" OD	270 lbs.

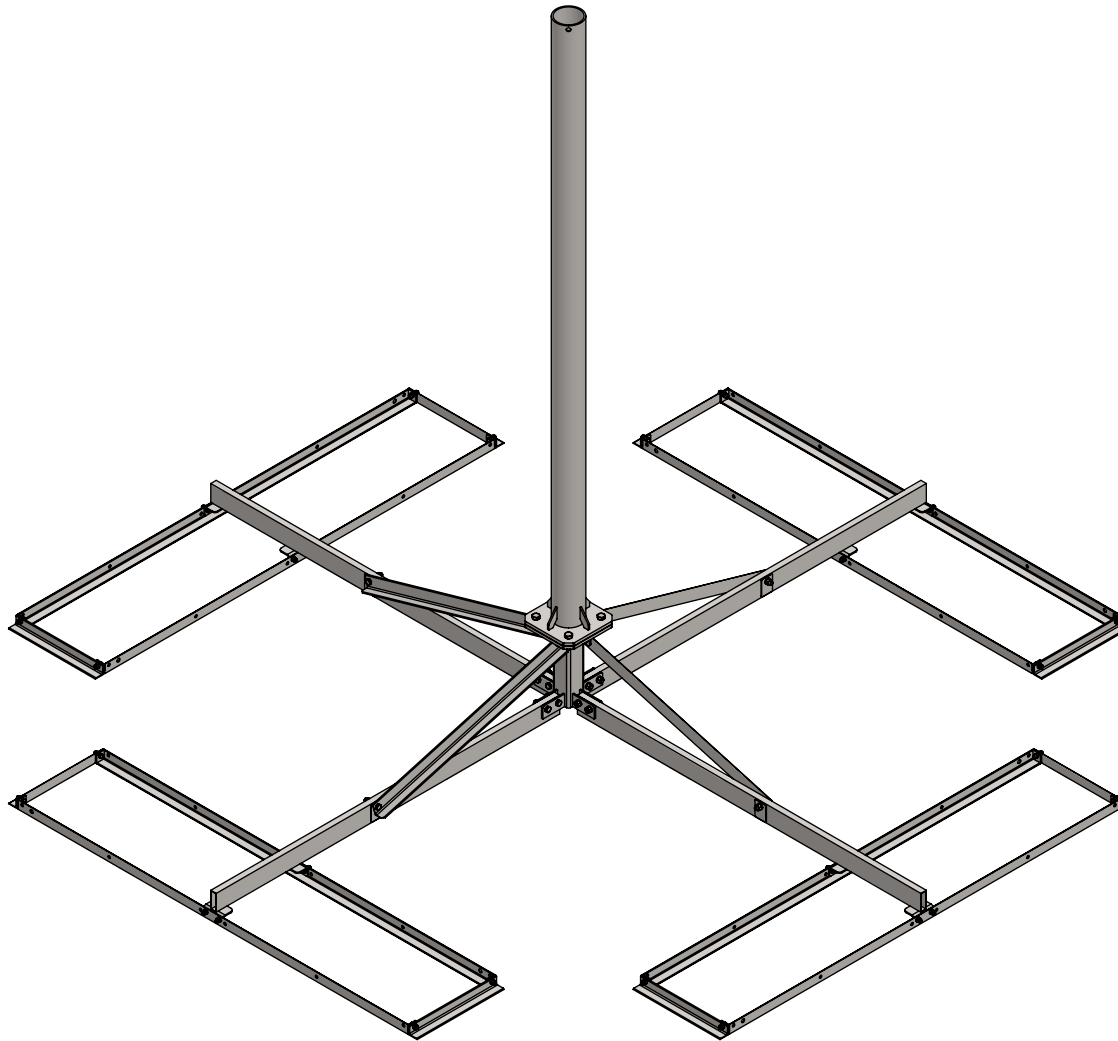

PROPRIETARY AND CONFIDENTIAL

THE INFORMATION CONTAINED IN THIS DRAWING IS THE SOLE PROPERTY OF BAIRD SUPPORTING SYSTEMS. ANY REPRODUCTION IN PART OR AS A WHOLE WITHOUT THE WRITTEN PERMISSION OF BAIRD SUPPORTING SYSTEMS IS PROHIBITED.



WWW.BAIRD MOUNTS.COM

UNLESS OTHERWISE SPECIFIED:

DIMENSIONS ARE IN INCHES

TOLERANCES:

FRACTIONAL ±

ANGULAR: MACH ± BEND ±

TWO PLACE DECIMAL ±

THREE PLACE DECIMAL ±

DO NOT SCALE DRAWING

BAIRD MOUNTING SYSTEMS

WATERLOO, IA 50703
PHONE: 319-233-3561
SALES@BAIRD MOUNTS.COM

DESCRIPTION:

B6-116 MOUNT WITH 8' MAST

DRAWN BY
JK

MATERIAL
STEEL

DWG. PURPOSE
CUSTOMER

DATE
02/17/22

FINISH
HDG

SHEET
1 OF 2

SCALE
-

PART. NO.
SEE TABLE

DWG. NO.
B6116-(000)X8

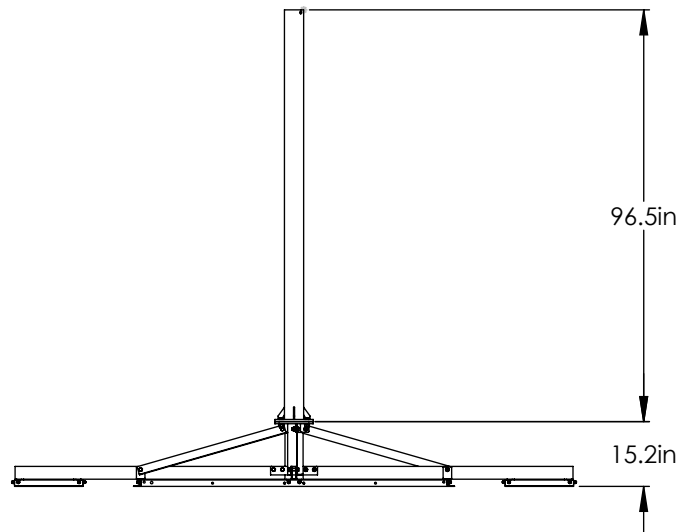
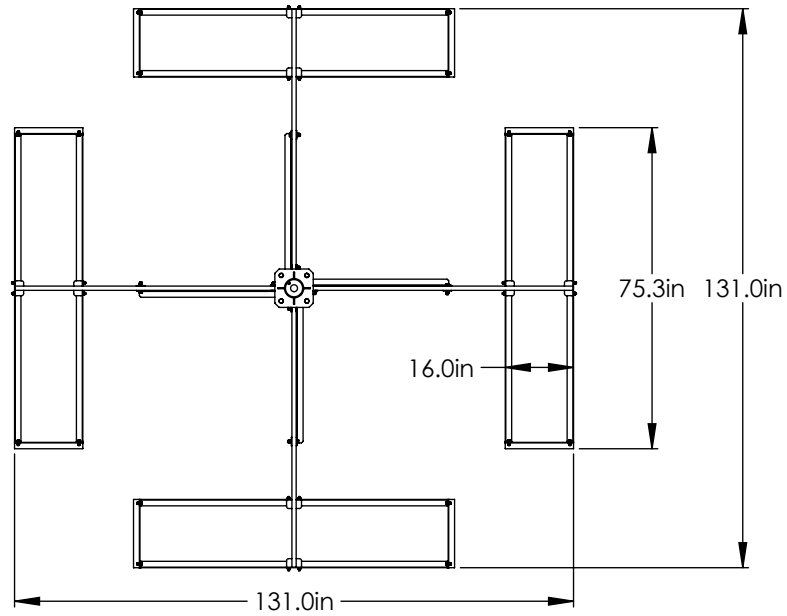

PROPRIETARY AND CONFIDENTIAL
 THE INFORMATION CONTAINED IN THIS DRAWING IS THE SOLE PROPERTY OF BAIRD SUPPORTING SYSTEMS. ANY REPRODUCTION IN PART OR AS A WHOLE WITHOUT THE WRITTEN PERMISSION OF BAIRD SUPPORTING SYSTEMS IS PROHIBITED.



WWW.BAIRD MOUNTS.COM

UNLESS OTHERWISE SPECIFIED:
 DIMENSIONS ARE IN INCHES
 TOLERANCES:
 FRACTIONAL ±
 ANGULAR: MACH ± BEND ±
 TWO PLACE DECIMAL ±
 THREE PLACE DECIMAL ±

DO NOT SCALE DRAWING

BAIRD MOUNTING SYSTEMS

WATERLOO, IA 50703
 PHONE: 319-233-3561
 SALES@BAIRDMOUNTS.COM

DESCRIPTION:
 B6-116 MOUNT WITH 8' MAST

DRAWN BY JK	DATE 02/17/22
MATERIAL STEEL	FINISH HDG
DWG. PURPOSE CUSTOMER	SHEET 2OF2
	SCALE -

PART. NO.
 SEE TABLE-SHEET 1

DWG. NO.
 B6116-(000)X8

PART NO.	MAST DIAMETER	WEIGHT
B6116-237X10	2.37" OD	218 lbs.
B6116-288X10	2.88" OD	240 lbs.
B6116-450X10	4.50" OD	292 lbs.

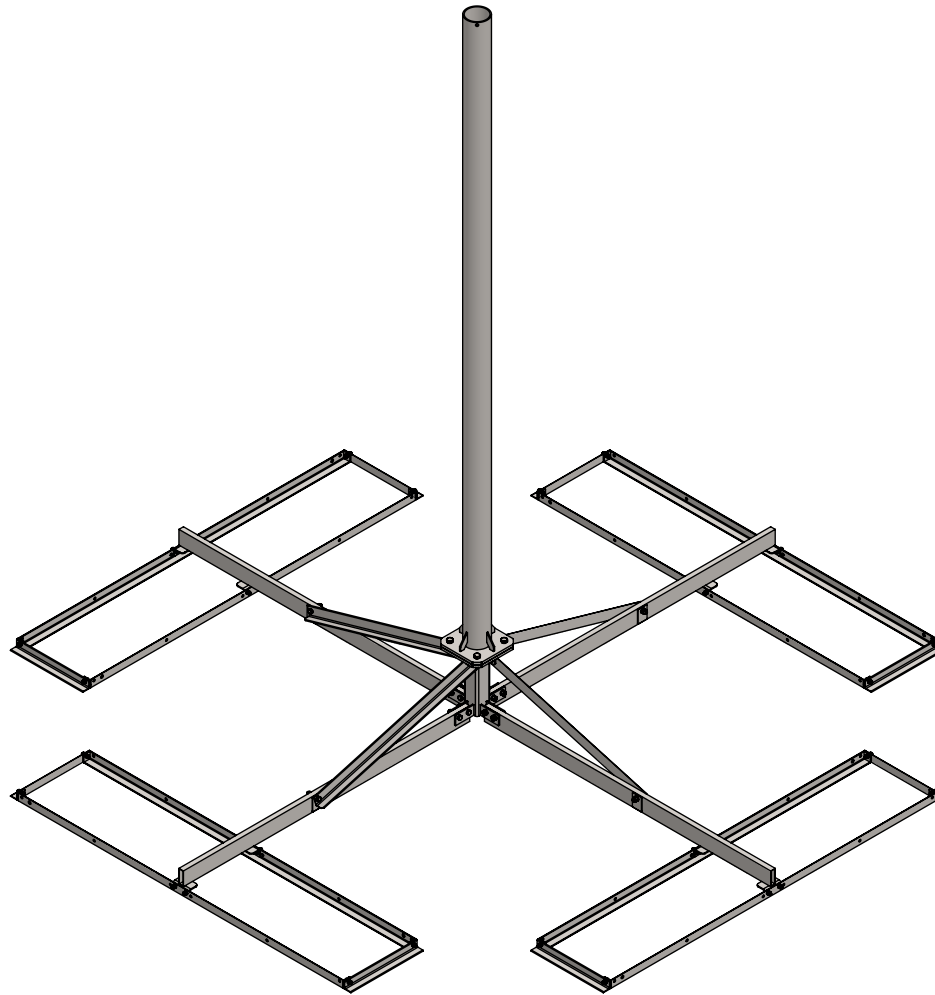

PROPRIETARY AND CONFIDENTIAL
 THE INFORMATION CONTAINED IN THIS DRAWING IS THE SOLE PROPERTY OF BAIRD SUPPORTING SYSTEMS. ANY REPRODUCTION IN PART OR AS A WHOLE WITHOUT THE WRITTEN PERMISSION OF BAIRD SUPPORTING SYSTEMS IS PROHIBITED.



WWW.BAIRD MOUNTS.COM

UNLESS OTHERWISE SPECIFIED:
 DIMENSIONS ARE IN INCHES
 TOLERANCES:
 FRACTIONAL ±
 ANGULAR: MACH ± BEND ±
 TWO PLACE DECIMAL ±
 THREE PLACE DECIMAL ±

DO NOT SCALE DRAWING

BAIRD MOUNTING SYSTEMS

WATERLOO, IA 50703
 PHONE: 319-233-3561
 SALES@BAIRD MOUNTS.COM

DESCRIPTION:
 B6-116 MOUNT WITH 10' MAST

DRAWN BY JK	DATE 02/17/22	
MATERIAL STEEL	FINISH HDG	
DWG. PURPOSE CUSTOMER	SHEET 1OF2	SCALE -
PART. NO. SEE TABLE		
DWG. NO. B6116-(000)X10		

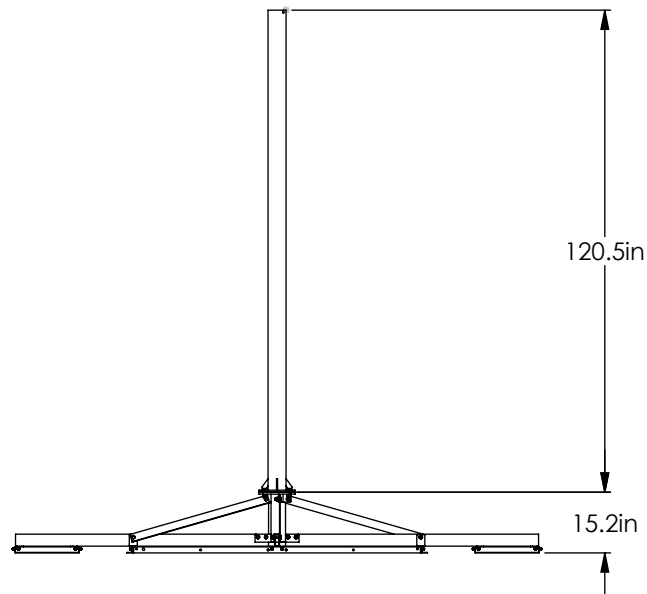
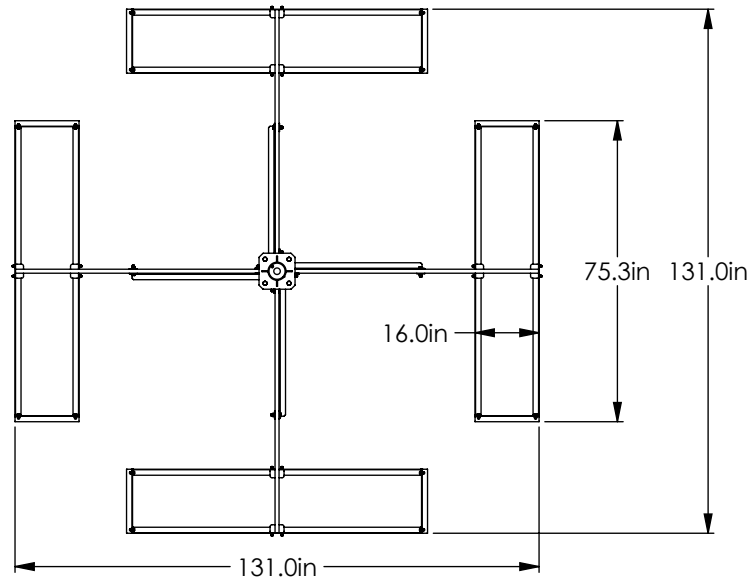

PROPRIETARY AND CONFIDENTIAL
 THE INFORMATION CONTAINED IN THIS DRAWING IS THE SOLE PROPERTY OF BAIRD SUPPORTING SYSTEMS. ANY REPRODUCTION IN PART OR AS A WHOLE WITHOUT THE WRITTEN PERMISSION OF BAIRD SUPPORTING SYSTEMS IS PROHIBITED.



WWW.BAIRD MOUNTS.COM

UNLESS OTHERWISE SPECIFIED:
 DIMENSIONS ARE IN INCHES
 TOLERANCES:
 FRACTIONAL ±
 ANGULAR: MACH ± BEND ±
 TWO PLACE DECIMAL ±
 THREE PLACE DECIMAL ±

DO NOT SCALE DRAWING

BAIRD MOUNTING SYSTEMS

WATERLOO, IA 50703
 PHONE: 319-233-3561
 SALES@BAIRD MOUNTS.COM

DESCRIPTION:
 B6-116 MOUNT WITH 10' MAST

DRAWN BY JK	DATE 02/17/22	
MATERIAL STEEL	FINISH HDG	
DWG. PURPOSE CUSTOMER	SHEET 2OF2	SCALE -

PART. NO.
 SEE TABLE-SHEET 1

DWG. NO.
 B6116-(000)X10